



**High Efficiency Air Filtration Equipment  
for Submicron Particulate, Aerosols and  
Volatile Organic Compounds**

**Verantis Corporation**  
HEAF® Gas Filtration Equipment

**Verantis Corporation**  
7251 Engle Road Suite 300  
Plaza South One  
Middleburg Heights OH 44130  
Toll Free: 800-554-8673  
Phone: 440-243-0700  
Fax: 440-243-9854

U.S. Patent Number 3,745,748  
U.S. Patent Number 4,073,631  
Numerous Foreign Patents

ULTRA HIGH EFFICIENCY  
REMOVAL OF AEROSOLS,  
VOC'S (VOLATILE ORGANIC COMPOUNDS)  
AND OTHER SUBMICRON PARTICULATES  
AND LIQUID DROPLETS

**TABLE OF CONTENTS**

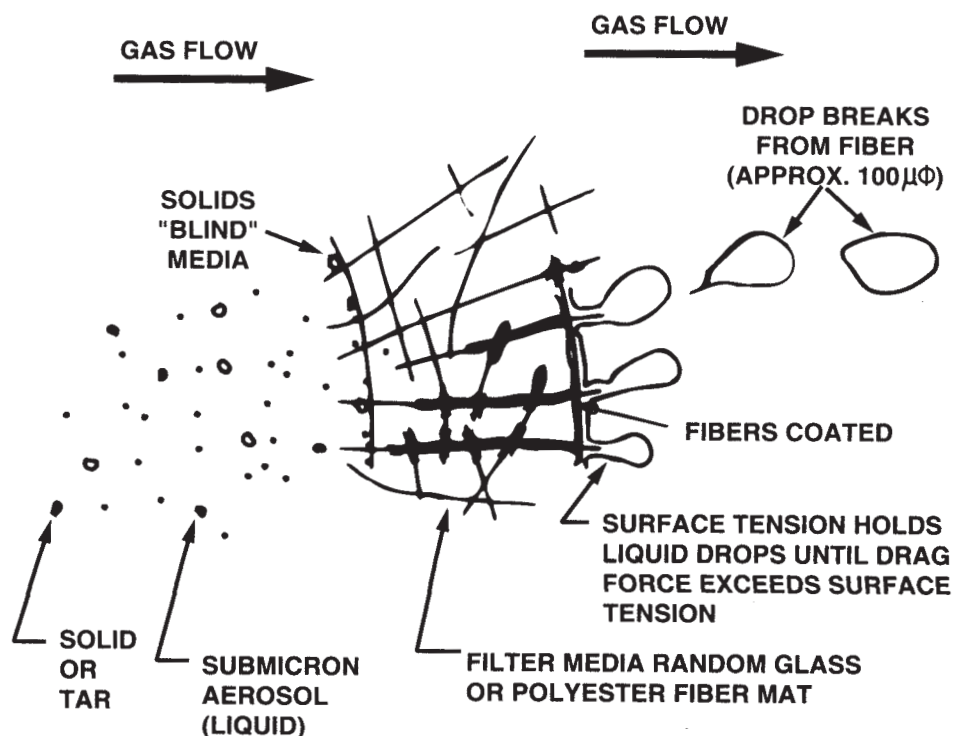
|                                                      |        |
|------------------------------------------------------|--------|
| HEAF DISPOSABLE MEDIA HIGH<br>EFFICIENCY AIR FILTERS | 2      |
| A. Mini-HEAF                                         | 3      |
| B. Flat-Bed HEAF                                     | 6      |
| C. Rotary Drum HEAF                                  | 10     |
| <br>COOLING CHAMBERS                                 | <br>14 |

## HEAF DISPOSABLE MEDIA HIGH EFFICIENCY AIR FILTERS

The Verantis HEAF air pollution control equipment line includes three different types of filtration devices for the removal of sticky, oily, or liquid aerosol particulate matter from exhaust gas streams. VOC's (volatile organic compounds) often are present in this form. These three units are the Mini-HEAF, the Flat-Bed HEAF, and the Rotary Drum HEAF. The Mini-HEAF is used for gas flows between 0 and 5,000 acfm at its inlet. The Flat-Bed HEAF unit is used for gas flows from 500 to 15,000 acfm at its inlet. The Rotary Drum or (DF) HEAF unit is used for gas flows from 9,000 to 100,000 acfm at its inlet. All of these HEAF units operate using the same collection mechanism and the same filtration media. The filter media is a fiberglass or polyester mat, made up of random fibers having a diameter of approximately 7 microns and a density of .066 oz /

ft<sup>2</sup>. The gas is drawn through the filter media at a face velocity of between 1,300 and 1,800 ft./min. The filter media is about 1/8" thick under these flow conditions. Particulate matter impacts on the fibers and is separated from the gas stream. Low viscosity liquids collected from the gas stream migrate through the filter media and are thrown off the back side of the filter media as larger liquid droplets. See Figure 1. These droplets pass through the exhaust fan, and are impacted on a mesh type mist separator at the fan exhaust. The more viscous compounds, which are collected on the filter media, remain in the filter media and eventually begin to blind it off. When gas flow through the filter media degrades to a predetermined level, the filter media is changed either manually or automatically to expose fresh filter media to the gas stream.

**FIGURE 1  
HEAF OPERATION**



**TABLE I  
SOURCES AND APPLICATIONS  
WHERE HEAF UNITS ARE OFTEN USED**

| SOURCE                                         | APPLICATION                                                              | FILTERING TEMP. |
|------------------------------------------------|--------------------------------------------------------------------------|-----------------|
| Abrasive Manufacture                           | Curing Ovens-Resin Aerosols                                              | 130°F *         |
| Adhesive Tape and Label Production             | Curing Ovens-Plasticizers                                                | 120°F *         |
| Asphalt Roofing Process                        | Coaters, Saturators & Storage Tank Vents-Oil Aerosols                    | 120°F *         |
| Asphalt Production                             | Blowing Still & Storage Tank Vents-Oil Aerosols                          | 120°F *         |
| Carbon Electrode Production                    | Paste Mixers-Oil & Tar Aerosols                                          | 100°F           |
| Coffee & Cocoa Production                      | Coffee & Cocoa Bean                                                      | 120°F *         |
| Commercial Printing                            | Ink Dryers-Solvent & Ink Aerosols                                        | 115°F *         |
| Fiberglass Insulation Production               | Curling Ovens & Forming Chambers Partially Polymerized Resin Aerosols    | 130°F *         |
| Flakeboard, Hardboard & Pressboard Manufacture | Hardwood Presses & Ovens-Wood Resins, Binders & Organic Acids            | 130°F *         |
| Food Processing                                | Vegetable Oil Fryers & Commercial Broilers-Vegetable Oil Aerosols & Fats | 150°F *         |
| Foundries                                      | Mold & Core Emissions-Phenolic Resins                                    | 100°F           |
| Glass Molding                                  | Mold Lubricants in Contact With Hot Glass-Oil Aerosols                   | 120°F           |
| Glove Manufacture                              | Vinyl & Rubber Drying Ovens Plasticizers & Oils                          | 120°F           |
| Heat Treating & Annealing                      | Quench Tanks-Oil Aerosols                                                | 120°F           |
| Meat Curing                                    | Smokehouses & Cookers-Smoke Aerosols & Fats                              | 120°F *         |
| Metal Forging                                  | Forge Hammers & Presses-Oil & Graphite Emissions                         | 140°F *         |
| Paper Converter                                | Calendar Roll Operations-Plasticizers & Resins                           | 100-110°F       |
| Plastic Coating                                | Vinyl Wallpaper & Vinyl Coated Fabric Curing Ovens-Plasticizers          | 120°F *         |
| Plastic Resin Manufacturing                    | Pellet Extruders & Fiber Extruders-Plasticizers                          | 130°F           |
| Rubber Molded Products                         | Mold & Press Emissions-Oils                                              | 120°F           |
| Scrap Metal Processor                          | Automobile Shredders Engine & Transmission Oil Aerosols                  | 80°F            |
| Soap & Detergent Manufacture                   | Heating & Cooking Operations-Fatty Acids & Alcohols                      | 120°F           |
| Soldering Operations                           | Solder Resins in Commercial Tank Soldering-Resin Aerosols                | 110°F           |
| Tank Vents                                     | Oil, Tar, Resin, and Sulfur Hot Storage Tanks-Aerosols                   | 120°F           |
| Textile Manufacturing                          | Tenter Frames-Solvent & Ink Aerosols                                     | 120°F *         |
| Tire Manufacturing                             | Vulcanizing Ovens-Plasticizers & Oils                                    | 120°F *         |
| Weatherstrip Manufacture                       | Curing Ovens-Plasticizers                                                | 140°F *         |
| Wire & Tube Manufacture                        | Wire & Tube Drawing Lubricant & Coolant Aerosols                         | 120°F           |

\*Cooling chamber required to achieve this temperature.

HEAF units are used to collect particulate matter in applications where baghouses will plug up due to the sticky, liquid nature of the particulate matter which has such a small size distribution that wet scrubbers require excessively high differential pressures to collect it. They are also used to collect particulate matter which cannot be easily removed from the collection plates in an electrostatic precipitator due to high conductivity or high water content. HEAF units can also collect particulate matter which has an improper resistivity to carry an electrostatic charge. Finally, HEAF units have been used to replace fume incinerators, particularly in recent years, to eliminate the high cost associated with fuel for the incinerators. Table I provides a list of typical HEAF applications and sources of emissions which HEAF units are particularly well suited to control. Each of the HEAF units is discussed below:

### Mini-HEAF

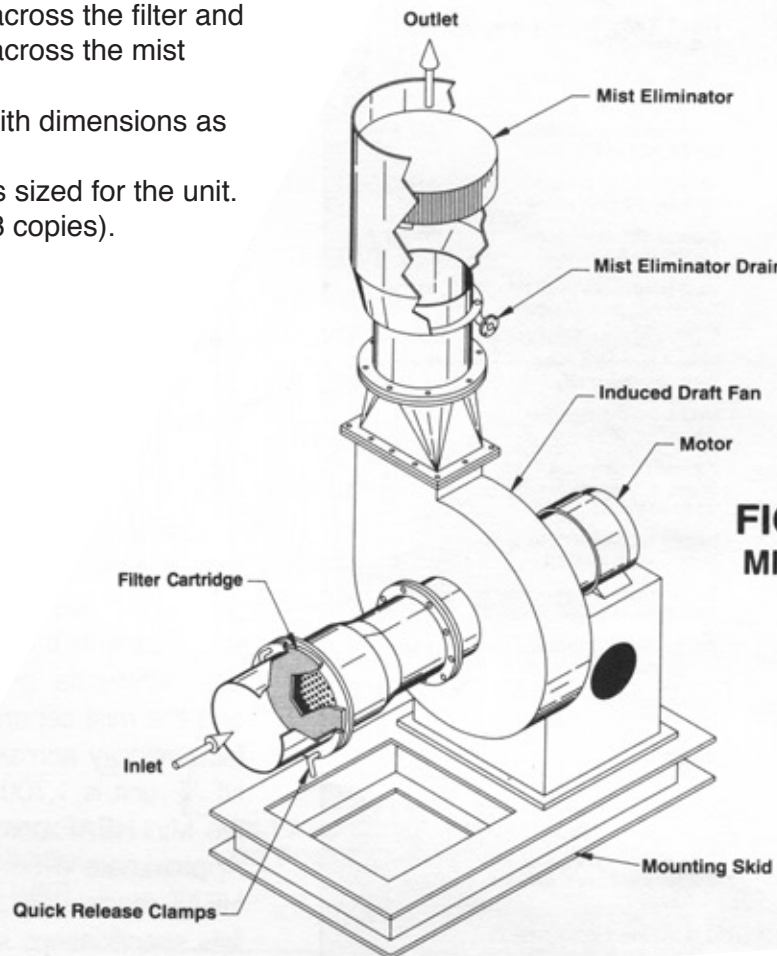
The Mini-HEAF is a manually operated filtration device. A round cartridge filter with a reinforcing ring around its perimeter is inserted between two flanged faces, and quick-opening clamps are used to pull the two flanges together, compressing the filter media to about 1/4" thick. The filter media is supported on its back side by a rigid screen. The filter holder is connected to the inlet of a centrifugal fan which provides draft across the filter and exhausts gases to a mist separator. The standard fan supplied with the Mini-HEAF unit produces a total differential pressure across the filter media and the mist separator of 35" H<sub>2</sub>O. The average face velocity across the filter media in the Mini-HEAF unit is 1,700 ft./min. A pictorial drawing of the Mini-HEAF unit is shown in Figure 2. Approximate dimensions of the various Mini-HEAF models are shown in Figure 3. Table II lists specifications for the Mini-HEAF units.

Mini-HEAFS are used in applications where the emissions are intermittent, or where gas flows are quite small and the customer desires the lowest possible capital cost unit. Mini-HEAFS should not be used in applications where filter life is found to be short. The operator attention required in applications where filter life is short increases operating costs to prohibitively high levels. The Mini-HEAF units listed in Table II include the following items:

1. Mild steel filter holder with quick release clamps.
2. Heavy duty pressure fan, Arrangement #4, with necessary 460 volt, 3 phase, 60 Hz drive motor. Fans include scroll drains. Mild steel construction.
3. Fan mounted mist eliminator with Type 304 S.S. mesh pad and mild steel housing. Models VIII-40 and IX-50 require separate support (by customer) for mist separator. Flexible connector is provided between fan and mist separator for these two models.
4. Mounting skid.
5. Manometer test connections for reading differential pressure across the filter and differential pressure across the mist separator.
6. An inlet connection with dimensions as shown in Figure 3.
7. Twenty filter elements sized for the unit.
8. Operating manuals (3 copies).

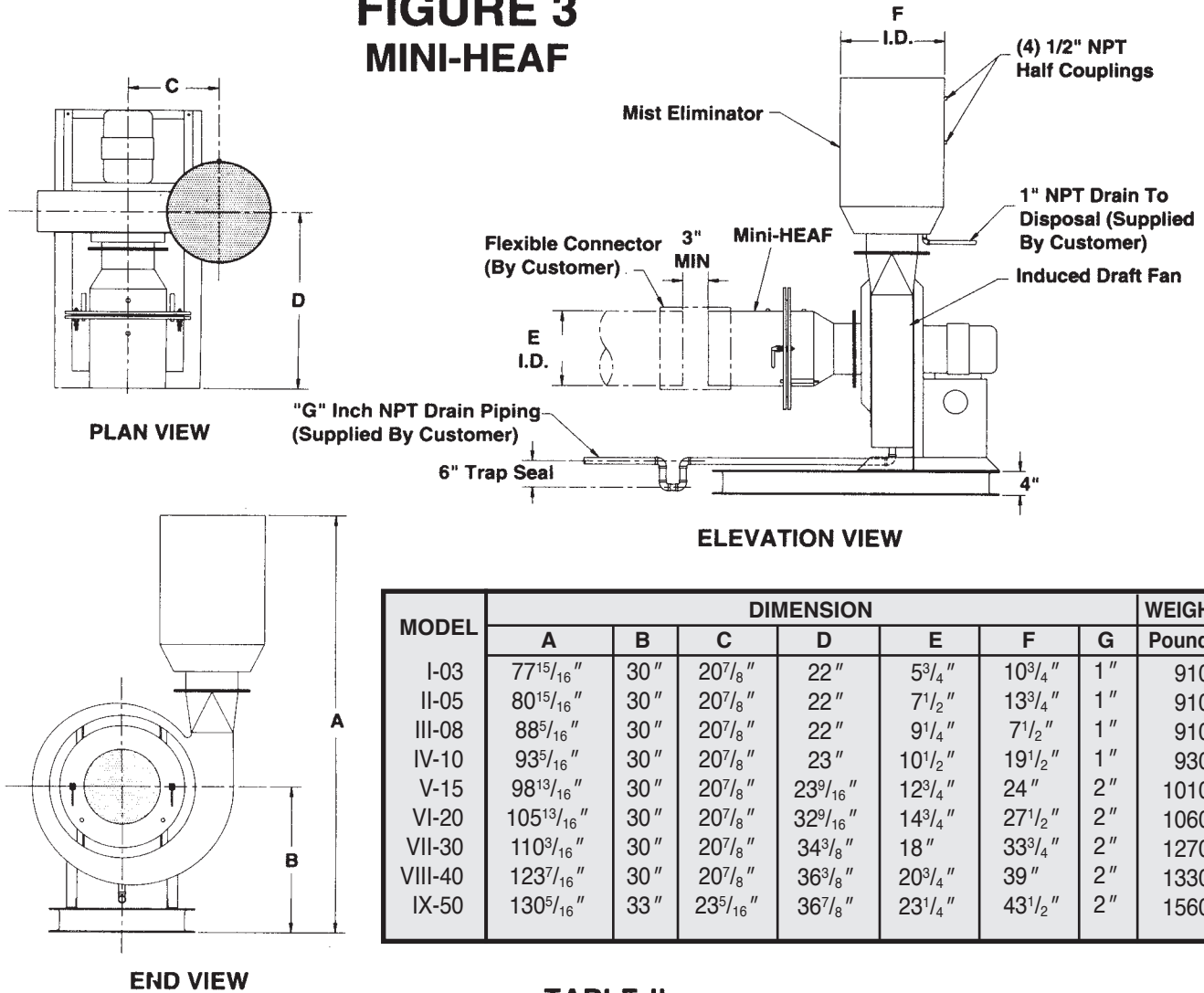
The customer must provide the necessary motor starter for the fan, any exhaust stack or exhaust duct connection, drain piping from the fan scroll drain, and a flexible inlet duct connection which will allow the filter holder to move forward approximately 2" for replacement of the filter media.

As with all HEAF units, the filter media can only remove particulate matter which exists as either a solid or liquid particulate in the gas stream. Gas phase compounds which have not condensed from the gas stream will not be filtered by the HEAF units. Typically, in applications where oil mists are involved, it is necessary to reduce the gas temperature to approximately 120°F to condense most of the organic compounds before filtration. Gas cooling can be accomplished using dilution air, or by using evaporative coolers to adiabatically cool the gas. Verantis Inc. can supply a full line of gas coolers for use with the HEAF units.



**FIGURE 2  
MINI-HEAF**

### FIGURE 3 MINI-HEAF



| MODEL   | DIMENSION                           |     |                                   |                                   |                                  |                                  |    | WEIGHT |
|---------|-------------------------------------|-----|-----------------------------------|-----------------------------------|----------------------------------|----------------------------------|----|--------|
|         | A                                   | B   | C                                 | D                                 | E                                | F                                | G  | Pounds |
| I-03    | 77 <sup>15</sup> / <sub>16</sub> "  | 30" | 20 <sup>7</sup> / <sub>8</sub> "  | 22"                               | 5 <sup>3</sup> / <sub>4</sub> "  | 10 <sup>3</sup> / <sub>4</sub> " | 1" | 910    |
| II-05   | 80 <sup>15</sup> / <sub>16</sub> "  | 30" | 20 <sup>7</sup> / <sub>8</sub> "  | 22"                               | 7 <sup>1</sup> / <sub>2</sub> "  | 13 <sup>3</sup> / <sub>4</sub> " | 1" | 910    |
| III-08  | 88 <sup>5</sup> / <sub>16</sub> "   | 30" | 20 <sup>7</sup> / <sub>8</sub> "  | 22"                               | 9 <sup>1</sup> / <sub>4</sub> "  | 7 <sup>1</sup> / <sub>2</sub> "  | 1" | 910    |
| IV-10   | 93 <sup>5</sup> / <sub>16</sub> "   | 30" | 20 <sup>7</sup> / <sub>8</sub> "  | 23"                               | 10 <sup>1</sup> / <sub>2</sub> " | 19 <sup>1</sup> / <sub>2</sub> " | 1" | 930    |
| V-15    | 98 <sup>13</sup> / <sub>16</sub> "  | 30" | 20 <sup>7</sup> / <sub>8</sub> "  | 23 <sup>9</sup> / <sub>16</sub> " | 12 <sup>3</sup> / <sub>4</sub> " | 24"                              | 2" | 1010   |
| VI-20   | 105 <sup>13</sup> / <sub>16</sub> " | 30" | 20 <sup>7</sup> / <sub>8</sub> "  | 32 <sup>9</sup> / <sub>16</sub> " | 14 <sup>3</sup> / <sub>4</sub> " | 27 <sup>1</sup> / <sub>2</sub> " | 2" | 1060   |
| VII-30  | 110 <sup>3</sup> / <sub>16</sub> "  | 30" | 20 <sup>7</sup> / <sub>8</sub> "  | 34 <sup>3</sup> / <sub>8</sub> "  | 18"                              | 33 <sup>3</sup> / <sub>4</sub> " | 2" | 1270   |
| VIII-40 | 123 <sup>7</sup> / <sub>16</sub> "  | 30" | 20 <sup>7</sup> / <sub>8</sub> "  | 36 <sup>3</sup> / <sub>8</sub> "  | 20 <sup>3</sup> / <sub>4</sub> " | 39"                              | 2" | 1330   |
| IX-50   | 130 <sup>5</sup> / <sub>16</sub> "  | 33" | 23 <sup>5</sup> / <sub>16</sub> " | 36 <sup>7</sup> / <sub>8</sub> "  | 23 <sup>1</sup> / <sub>4</sub> " | 43 <sup>1</sup> / <sub>2</sub> " | 2" | 1560   |

**TABLE II**  
**Mini-HEAF**  
**Models, Gas Flows, Specifications**

| MODEL#  | GAS FLOW<br>AT INLET | MOTOR<br>HORSEPOWER | INLET<br>DIAMETER                | FILTER<br>CARTRIDGE | OUTLET<br>DIAMETER               |
|---------|----------------------|---------------------|----------------------------------|---------------------|----------------------------------|
| I-03    | 0-300 ACFM           | 10 TEFC             | 5 <sup>3</sup> / <sub>4</sub> "  | 12"φ                | 10 <sup>3</sup> / <sub>4</sub> " |
| II-05   | 301-500 ACFM         | 10 TEFC             | 7 <sup>1</sup> / <sub>2</sub> "  | 12"φ                | 13 <sup>3</sup> / <sub>4</sub> " |
| III-08  | 501-800 ACFM         | 10 TEFC             | 9 <sup>1</sup> / <sub>4</sub> "  | 12"φ                | 17 <sup>1</sup> / <sub>2</sub> " |
| IV-10   | 801-1,000 ACFM       | 15 TEFC             | 10 <sup>1</sup> / <sub>2</sub> " | 15"φ                | 19 <sup>1</sup> / <sub>2</sub> " |
| V-15    | 1,001-1,500 ACFM     | 20 TEFC             | 12 <sup>3</sup> / <sub>4</sub> " | 15"φ                | 24"                              |
| VI-20   | 1,501-2,000 ACFM     | 25 TEFC             | 14 <sup>3</sup> / <sub>4</sub> " | 20"φ                | 27 <sup>1</sup> / <sub>2</sub> " |
| VII-30  | 2,001-3,000 ACFM     | 40 TEFC             | 18"                              | 20"φ                | 33 <sup>3</sup> / <sub>4</sub> " |
| VIII-40 | 3,001-4,000 ACFM     | 50 TEFC             | 20 <sup>3</sup> / <sub>4</sub> " | 26"φ                | 39"                              |
| IX-50   | 4,001-5,000 ACFM     | 60 TEFC             | 23 <sup>1</sup> / <sub>4</sub> " | 26"φ                | 43 <sup>1</sup> / <sub>2</sub> " |

Note: All Mini-HEAFS use 35" H<sub>2</sub>O differential pressure across filter media. All include mist separator and housing. All use Arrangement #4 fans (fan wheel mounted on motor shaft). All assume air with 20% relative humidity at 120°F at inlet. Models VIII-40 and IX-50 require separate support (by customer) for the mist separator. Flexible connectors are provided with these models between fan discharge and mist separator inlet.

### Flat-Bed HEAF

The lowest cost, fully automatic HEAF unit is the Flat-Bed HEAF. This unit is designed for gas flows ranging from 500 acfm to 15,000 acfm. The flat-Bed unit, depending on gas flow being processed, uses filter media varying from 18" to 48" wide. All filter media is provided in 275 ft. or 525 ft. rolls. The Flat-Bed HEAF unit is pictured in Figure 4. Figure 5 shows approximate dimensions of the various Flat-Bed HEAF units. Table III provides specifications for the various Flat-Bed Units.

The Flat-Bed HEAF unit utilizes a flat perforated plate across which a wire screen is advanced, on an intermittent basis, to advance filter media into the gas stream. The screen is tensioned with an idler roll outside of the HEAF cabinet. The Flat-Bed HEAF unit is typically operated at a differential pressure across the filter media of 28" H<sub>2</sub>O. Filtration velocities at the face of the filter mat vary between 1,500 and 1,700 ft./min. As the filter media enters the filtration cabinet, it passes under a curved stainless steel seal which limits the fresh air leakage into the cabinet. As the filter media exits the cabinet, it passes under another identical stainless steel seal.

If inlet pressure to the HEAF cabinet becomes too negative, excess dilution air will be drawn in through these seals, and the filtration unit tends to draw the filter media in through the seals and ravel it up on the perforated plate. Thus, it is necessary to ensure that the differential pressure across the ductwork leading into the Flat-Bed HEAF unit is low enough to prevent negative pressures in excess of about 8" W.G. from developing at the inlet to the HEAF unit. If total ductwork requires higher differential pressures to achieve proper inlet gas flows, a booster fan can be installed at the inlet duct to the HEAF unit.

Because filter media can be provided automatically in the Flat-Bed unit, and because filter media is relatively inexpensive, 28" W.G. differential pressure is used for the Flat-Bed HEAF units. Filter life is reduced slightly from the Mini-HEAF unit, but power consumption is reduced sub-

stantially, and the operating costs are actually reduced using the Flat-Bed unit. In special instances, where filter life is extremely short, the Flat-Bed unit can be operated with higher differential pressure fans to extend filter life. The Flat-Bed HEAF units discussed in Table III include the following equipment items:

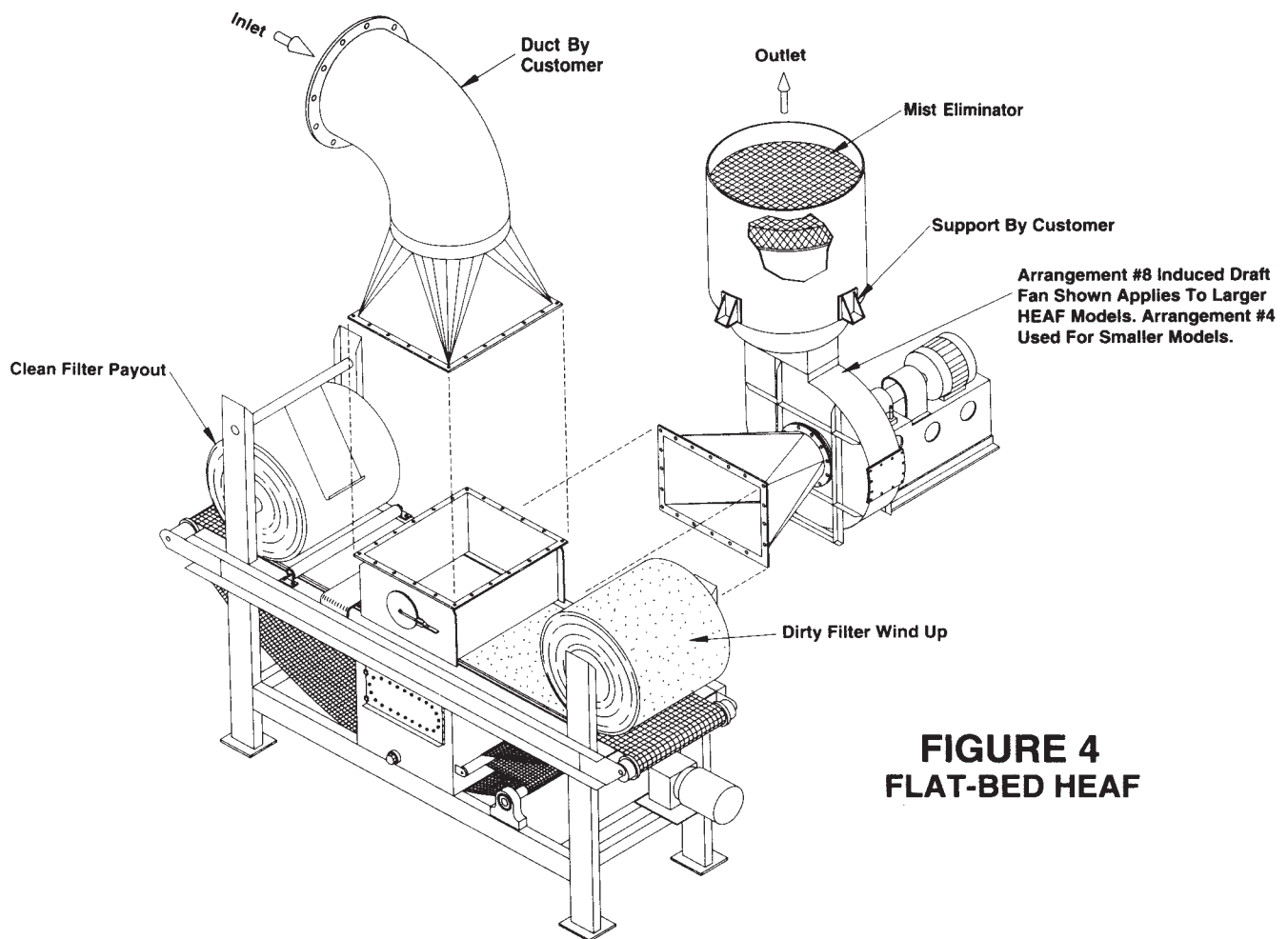
1. Main filter unit with support stand, filter drive, TEFC motor, and cabinet drain. Mild steel construction.
2. Filter payout (with splicing table) and windup assemblies for automatic operation.
3. Required high pressure (rated at 28: W.G. differential pressure), centrifugal fan with motor and drive to provide necessary gas flow at the inlet to the Flat-Bed HEAF unit. Flat-Bed HEAF fans are either Arrangement #4 or Arrangement #8. Motors supplied are 460 volt, 3 phase, 60 Hz. Fans for 5,000 acfm and larger gas flows have inspection doors. All fans have scroll drains and are mild steel construction.
4. Prewired control panel in which start-stop pushbuttons, pressure switch, fan motor current controller, selector switch, audible alarm, and relays are installed. NEMA 12 construction.
5. Across-the-line motor starters supplied in NEMA 12 enclosures for separate mounting.
6. Automatic filter indexing by either fan motor current control or negative pressure within the filter cabinet. Selector switch or control panel fixes mode of operation.
7. Two Magnehelic gauges - one 0-5" W.G. required for monitoring differential pressure across the mist separator, and one 0-40" W.G. to monitor pressure drop across the filter. One Photohelic pressure controller is provided for filter advance. Mounted in control panel.
8. Limit switch with audible alarm to indicate when filter media is running low.
9. Filter splicing supplies including stapler and staples.
10. Standard transition duct between filter cabinet and main fan inlet.
11. Standard duct from fan outlet to mist separator. Flexible connector provided for Models M-2.0-40 and larger.
12. Mist separator with Type 304 S.S. internals and mild steel housing.

13. Two rolls of required HEAF filter media.
14. Operating manuals (3 copies).
15. Two days of startup assistance, if required, after unit is fully installed and ready for startup. Assistance beyond this time is available at the prevailing service rate per day plus expenses.

The customer must furnish all necessary foundations, field wiring and piping, equipment installation, necessary structural supports for the mist separator which must be separately supported because of the flexible connector between the fan and the mist separator (Models M-2.0-40 and larger), inlet and outlet ductwork and, if mounted outdoors, a protective shed to

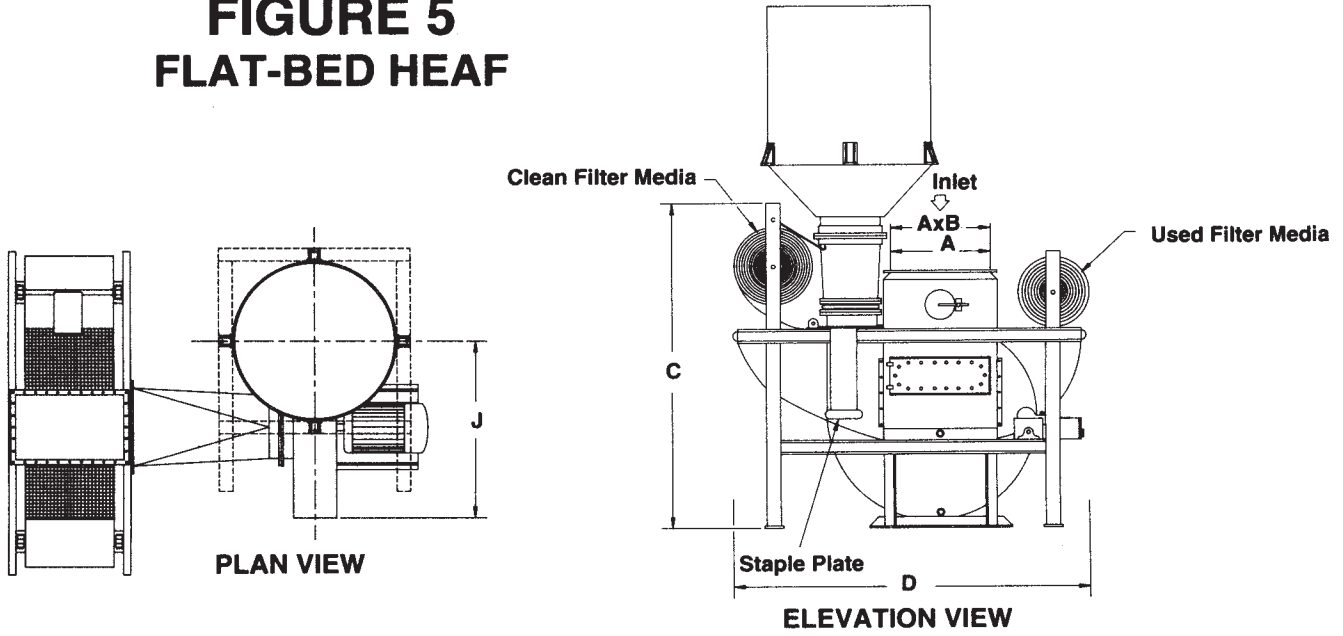
shield the filter media drive. The Flat-Bed HEAF unit can be used in virtually any application where the HEAF filtration principle applies. In some instances, where toxic materials must be removed from a small gas stream, or where small gas streams contain high concentrations of valuable materials, the Flat-Bed HEAF unit is considered for small gas flows, even with short filter lives (eg: arsenic, lead and cadmium emissions, asbestos fibers, and precious metals recoveries).

As with all other HEAF units, aerosols and liquids should be condensed before entering the filtration unit, to ensure maximum collection efficiency. Cooling chambers may be required.

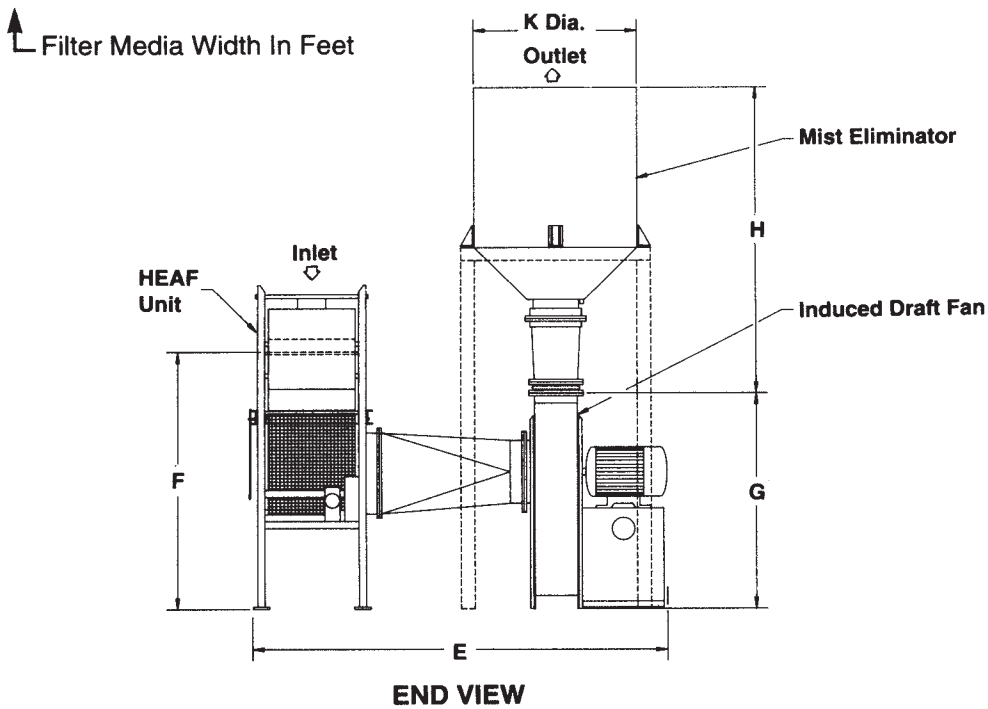


**FIGURE 4  
FLAT-BED HEAF**

**FIGURE 5  
FLAT-BED HEAF**



| MODEL NO. | INLET<br>CFM RANGE<br>X 1000 | A   | B   | C    | D     | E      | F     | G     | H     | J     | K   | EST.<br>WT.<br>lbs. | H.P. |
|-----------|------------------------------|-----|-----|------|-------|--------|-------|-------|-------|-------|-----|---------------------|------|
| M-1.5-10  | 0.5-1                        | 16" | 24" | 7'2" | 8'7"  | 6'7"   | 4'10" | 3'10" | 3'3"  | 3'5"  | 20" | 1720                | 10   |
| M-1.5-20  | 1-2                          | 16" | 24" | 7'2" | 8'7"  | 6'10"  | 4'10" | 3'10" | 3'11" | 3'5"  | 28" | 1890                | 20   |
| M-2.0-30  | 2-3                          | 27" | 30" | 7'2" | 9'6"  | 9'2"   | 4'10" | 3'10" | 4'5"  | 3'5"  | 34" | 2240                | 25   |
| M-2.0-40  | 3-4                          | 27" | 30" | 7'2" | 9'6"  | 9'2"   | 4'10" | 3'10" | 4'11" | 3'5"  | 39" | 2595                | 40   |
| M-2.0-50  | 4-5                          | 27" | 30" | 7'2" | 9'6"  | 9'2"   | 4'10" | 3'10" | 5'3"  | 3'10" | 44" | 2850                | 40   |
| M-3.0-70  | 5-7                          | 29" | 42" | 7'2" | 9'8"  | 12'2"  | 4'10" | 3'6"  | 6'1"  | 2'9"  | 53" | 3600                | 60   |
| M-3.0-90  | 7-9                          | 29" | 42" | 7'2" | 9'8"  | 12'2"  | 4'10" | 3'6"  | 6'8"  | 3'2"  | 60" | 3995                | 75   |
| M-4.0-100 | 9-10                         | 33" | 54" | 7'5" | 10'5" | 18'10" | 5'2"  | 7'1"  | 7'11" | 8'7"  | 66" | 7290                | 75   |
| M-4.0-120 | 10-12                        | 33" | 54" | 7'5" | 10'5" | 18'10" | 5'2"  | 7'1"  | 8'5"  | 8'7"  | 72" | 7650                | 100  |
| M-4.0-150 | 12-15                        | 33" | 54" | 7'5" | 10'5" | 18'10" | 5'2"  | 7'1"  | 8'10" | 8'7"  | 78" | 8195                | 125  |



**TABLE III  
Flat Bed-HEAF  
Models, Gas Flows, Specifications**

| <b>MODEL#</b> | <b>GAS FLOW<br/>AT INLET</b> | <b>FILTER MEDIA<br/>WIDTH</b> | <b>MAIN FAN<br/>MOTOR<br/>HORSEPOWER</b> |
|---------------|------------------------------|-------------------------------|------------------------------------------|
| M-1.5-10      | 501-1,000 ACFM               | 18"                           | 10 TEFC                                  |
| M-1.5-20      | 1,001-2,000 ACFM             | 18"                           | 20 TEFC                                  |
| M-2.0-30      | 2,001-3,000 ACFM             | 24"                           | 25 TEFC                                  |
| M-2.0-40      | 3,001-4,000 ACFM             | 24"                           | 40 TEFC                                  |
| M-2.0-50      | 4,001-5,000 ACFM             | 25"                           | 40 TEFC                                  |
| M-3.0-70      | 5,001-7,000 ACFM             | 36"                           | 60 TEFC                                  |
| M-3.0-90      | 7,001-9,000 ACFM             | 36"                           | 75 TEFC                                  |
| M-4.0-100     | 9,001-10,000 ACFM            | 48"                           | 100 TEFC                                 |
| M-4.0-120     | 10,001-12,000 ACFM           | 48"                           | 100 TEFC                                 |
| M-4.0-150     | 12,001-15,000 ACFM           | 48"                           | 125 TEFC                                 |

Note: All above use 28" W.G. differential pressure across filter media. All except the M-3.0 and M-4.0 Models use Arrangement #4 fans. These two Models use Arrangement #8 fans. All assume air with 20% relative humidity at 120°F at inlet.

### Rotary Drum (DF) HEAF

The Rotary Drum HEAF unit is a fully automatic unit designed for gas flows ranging from 9,000 acfm to 100,000 acfm. The Rotary Drum unit, depending on gas flow being processed, uses filter media varying from 2' wide to 4' wide. All filter media is provided in 275 ft. or 525 ft. rolls. The Rotary Drum (DF) unit is pictured in Figure 6. Figure 7 shows approximate dimensions of the various Rotary Drum HEAF units. Table IV provides specifications for the various Rotary Drum units. The Rotary Drum HEAF unit utilizes a cylindrical perforated drum around which a wire belt is wrapped. The wire belt exits the filtration cabinet at the bottom of the cabinet, passes around an adjustable tension idler roll, and re-enters the filter cabinet on an upward slope at about mid-point in the front of the cabinet. Movement of the belt is provided by movement of the rotary drum, which is driven by a small horsepower gearmotor mounted at the end of the drum opposite the fan suction. The filter media rides on this belt and is drawn around the Filter drum by the belt. At the point where the belt and the filter media enter the cabinet, a curved stainless steel plate compresses the filter media and acts as a seal to prevent air from leaking into the cabinet. The same type of seal mechanism is provided at the exit point for the belt and the filter media. Figure 8 shows the drum and belt mechanism used in the Rotary Drum unit. Two hundred fifty degrees of the drum is used as an active filtration surface. The remaining 110 degrees does not provide a filtration surface because it is contained in the space between the two seals, and because it has no filter media on it.

The Rotary Drum HEAF unit is typically operated at a differential pressure across the filter media of 28" W.G. Filtration velocities at the face of the filter may vary between 1,500 and 1,700 ft./min. Just as with the Flat Bed HEAF unit, it is necessary to ensure that the differential pressure in the ductwork leading into the Rotary Drum HEAF unit is low enough to prevent negative pressures in excess of about 8" W.G. from developing at the inlet to the HEAF unit. If the inlet ductwork requires more pressure to achieve such an inlet

condition, a booster fan can be installed in the inlet duct to the HEAF Unit.

Because filter media can be advanced automatically in the rotary Drum unit (just as in the Flat-Bed unit), and because filter media is relatively inexpensive, the 28" W.G. differential pressure is selected instead of the 35" W.G. differential pressure used for the Mini-HEAF. Filter life is reduced slightly from this unit, but power consumption is reduced substantially, and operating costs are normally reduced from the Mini-HEAF when the rotary Drum unit is used. In special instances, where filter life is extremely short, the Rotary drum unit can be operated with higher differential pressure fans to extend filter life.

The Rotary Drum HEAF units discussed in Table IV include the following equipment items:

1. Main filter unit with support stand, filter drive, TEFC motor, and cabinet drain.
2. Filter payout (with splicing table) and wind-up assemblies for automatic operation.
3. Required high pressure (rated at 28" W.G. differential pressure), centrifugal fan with motor and drive, to provide necessary gas flow at the inlet to the Rotary Drum HEAF unit. Rotary Drum HEAF fans are Arrangement #8, unless otherwise noted. Motors supplied are 460 volt, 3 phase, 60 Hz up through 300 H.P., and 4160 volt, 3 phase, 60 Hz above 300 H.P. All fans have inspection doors, coupling guard, and scroll drains. The larger fans can be furnished with split housings.
4. Prewired control panel in which start-stop pushbutton, pressure switches, motor current controller, selector switch, audible alarm, and relays are installed. NEMA 12 construction.
5. Across-the-line motor starters in NEMA 12 enclosures for separate mounting.
6. Automatic filter indexing by either motor current controller or negative pressure within the filter cabinet. Selector switch on control panel fixes mode of operation.
7. Mist separator and housing with access doors and drain connection to be installed on fan discharge.

8. Limit switch with audible alarm to indicate when filter media is running low.
9. Filter splicing supplies including stapler and staples.
10. HEAF cabinet-to-fan transition duct.
11. Exit duct from fan to mist separator inlet with flexible connector.
12. Two rolls of required HEAF filter media.
13. Two Magnehelic gauges and one Photohelic gauge - one 0-5" W.G. Magnehelic required for monitoring differential pressure across the mist separator - one 0-5" W.G. Photohelic required for monitoring negative pressure in the filter cabinet - one 0-40" W.G. Magnehelic to monitor pressure drop across the filter.
14. Operating manuals (3 copies).
15. Two days of startup assistance, if required, after unit is fully installed and ready for startup. Additional startup assistance is provided at the prevailing service rate per day plus expenses.

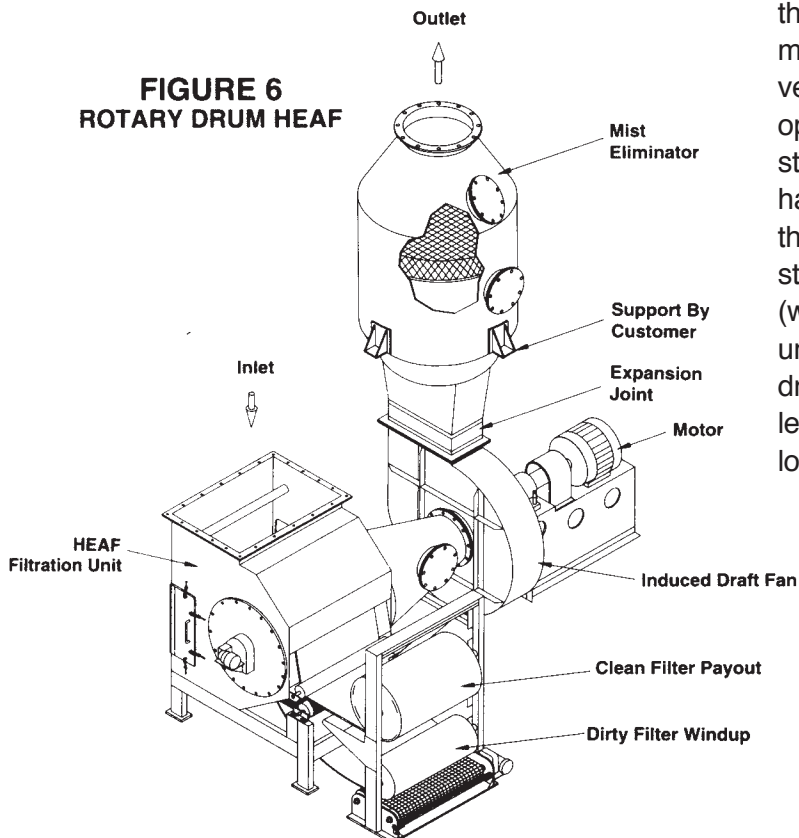
The customer must furnish all necessary foundations, field wiring and piping, equipment installation, necessary structural supports for the mist separator (which must be separately supported because of the flexible connector between the fan and the mist separator), inlet and outlet ductwork and, if mounted outdoors, a protective shed to shield the filter media drive.

The Rotary Drum HEAF unit is used in all HEAF applications where large gas flow rates must be processed. As with all other HEAF units, condensible materials should be condensed before entering the filtration unit to ensure maximum collection efficiency. Cooling chambers can be used with the Rotary Drum unit to reduce the temperature of the inlet gas to a temperature where these compounds are condensed.

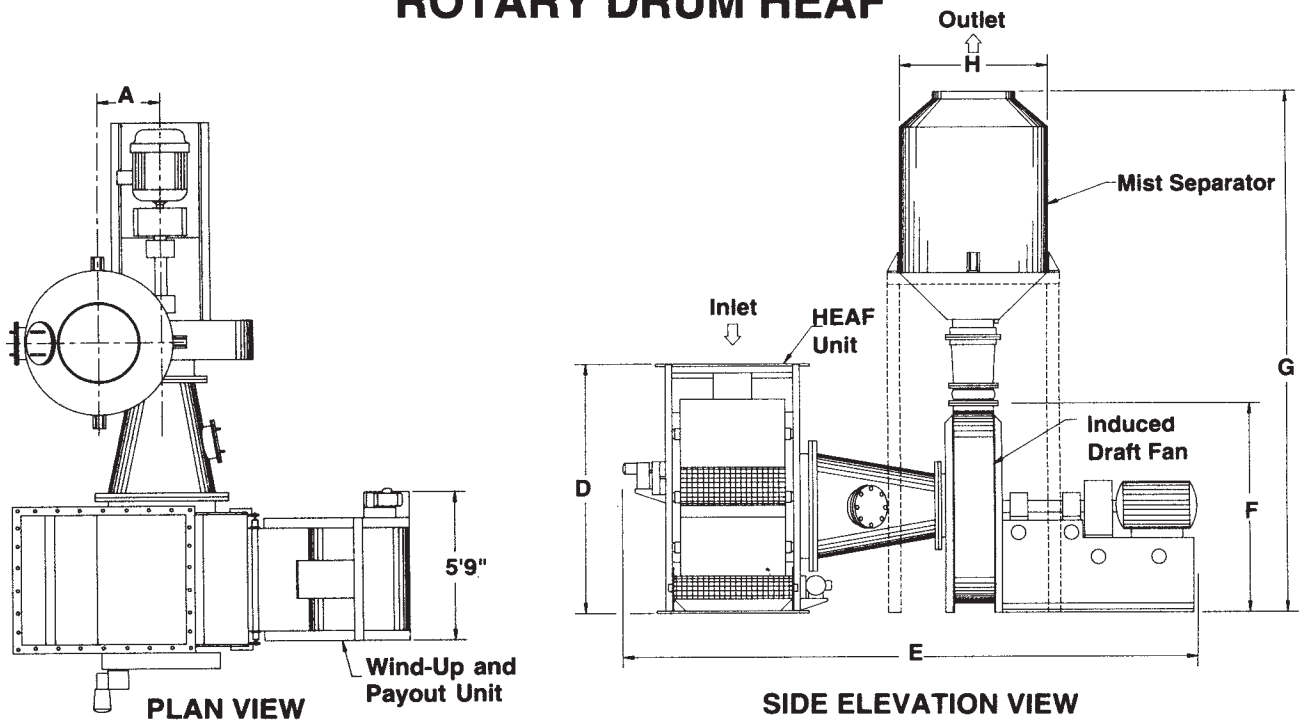
The Rotary Drum HEAF unit comes in four arrangements, two inlet possibilities, and two locations for the drum drive motor. A top inlet means the incoming ductwork will be flanged to the top of the HEAF cabinet. A back inlet means the ductwork connection is made to the vertical face of the HEAF cabinet, on the face opposite the filter media payout and windup stand. The unit is also described as either "right hand" or "left hand". This pertains to which side the drum drive motor is located on. When standing at the payout and windup stand (which is referred to as the "front" of the HEAF unit), and looking toward the HEAF cabinet, the drum drive motor can be located on either the left or right side of the unit. The main fan will be located on the opposite side of the drum drive.

The Rotary Drum HEAF unit can therefore be one of the four following configurations.

1. Top inlet - right hand
2. Top inlet - left hand
3. Back inlet - right hand
4. Back inlet - left hand



## FIGURE 7 ROTARY DRUM HEAF

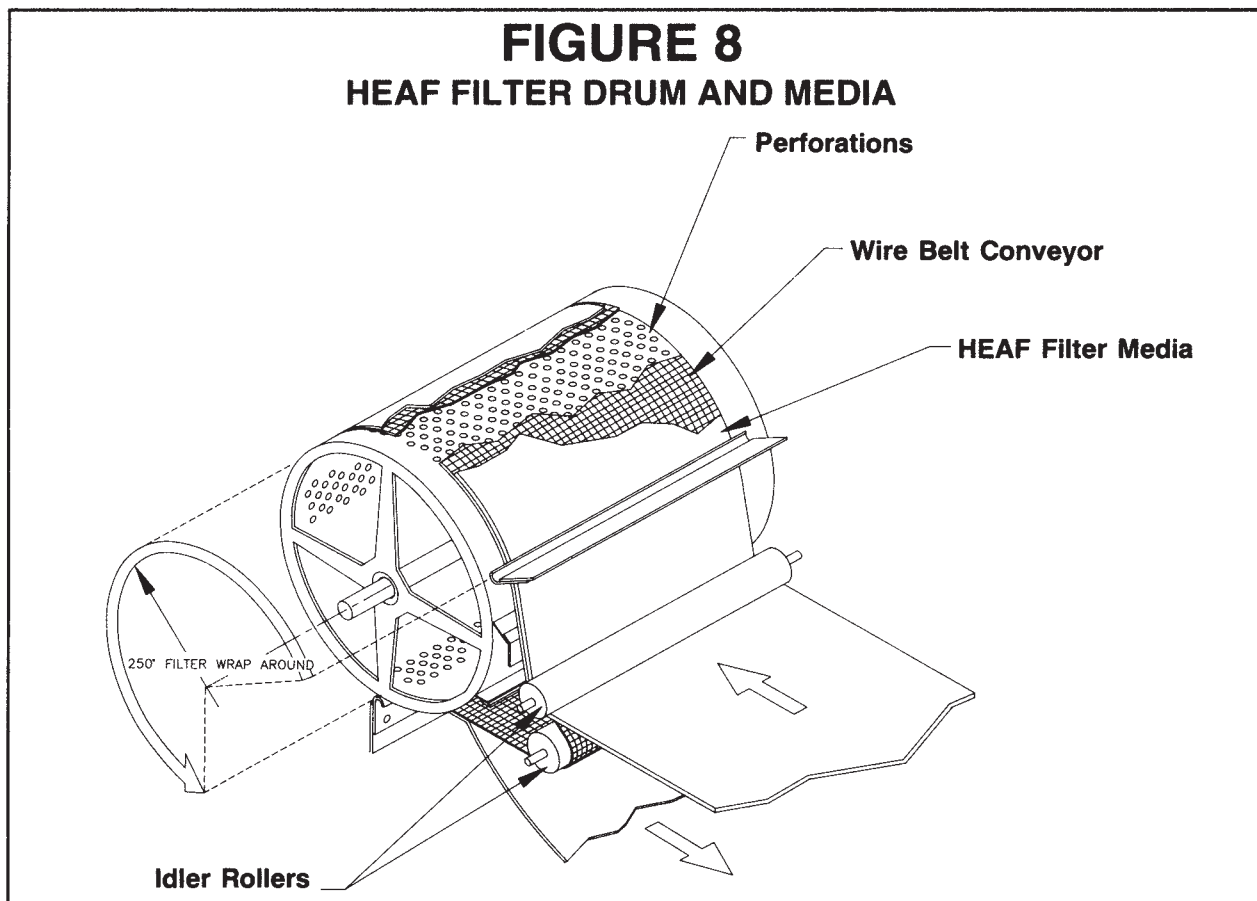


| MODEL NO. DF- | INLET CFM RANGE (1000's) | A     | B      | C     | D     | E     | F     | G      | H      | EST. Shp. Wt.lbs. |
|---------------|--------------------------|-------|--------|-------|-------|-------|-------|--------|--------|-------------------|
| 33-I          | 9-13                     | 1'11" | 10'10" | 6'10" | 7'4"  | 17'2" | 6'6"  | 17'0"  | 5'6"   | 6,500             |
| 33-II         | 13-17                    | 2'0"  | 10'10" | 6'10" | 7'4"  | 20'7" | 6'8"  | 20'5"  | 7'6"   | 9,900             |
| 33-III        | 17-22.5                  | 1'8"  | 10'10" | 6'10" | 7'4"  | 19'4" | 6'7"  | 22'11" | 8'6"   | 9,900             |
| 44-IV         | 22.5-30                  | 1'9"  | 11'9"  | 7'4"  | 8'9"  | 24'1" | 7'4"  | 24'9"  | 10'0"  | 17,100            |
| 44-V          | 30-41                    | 1'9"  | 11'9"  | 7'4"  | 8'9"  | 24'0" | 7'6"  | 26'11" | 11'0"  | 18,900            |
| 54-VI         | 41-52                    | 4'1"  | 13'9"  | 7'11" | 9'5"  | 26'7" | 10'6" | 28'2"  | 12'6"  | 35,000            |
| 64-VII        | 52-56                    | 4'1"  | 15'0"  | 9'2"  | 10'5" | 30'8" | 10'6" | 29'4"  | 13'0"  | 36,400            |
| 64-VIII       | 56-62                    | 4'1"  | 15'0"  | 9'2"  | 10'5" | 30'8" | 10'6" | 31'9"  | 13'4"  | 36,800            |
| 84-IX         | 62-100                   | 4'4"  | 16'3"  | 10'4" | 14'1" | 37'3" | 11'2" | 40'0"  | 16'10" | 42,900            |

**TABLE IV**  
**Verantis Inc. Model DF-HEAF Specifications**

| <b>MODEL#</b> | <b>GAS FLOW CAPACITY</b> | <b>TYPICAL MAIN FAN H.P.</b> | <b>MEDIA WIDTH</b> | <b>DRUM DIAMETER</b> |
|---------------|--------------------------|------------------------------|--------------------|----------------------|
| DF-33-I       | 9,000-13,000 ACFM        | 100 TEFC                     | 3 FT.              | 3FT.                 |
| DF-33-II      | 13,001-17,000 ACFM       | 125 TEFC                     | 3 FT.              | 3 FT.                |
| DF-33-III     | 17,001-22,500 ACFM       | 200 TEFC                     | 3 FT.              | 3 FT.                |
| DF-44-IV      | 22,501-30,000 ACFM       | 225 TEFC                     | 4 FT.              | 4 FT.                |
| DF-44-V       | 30,001-41,000 ACFM       | 300 TEFC                     | 4 FT.              | 4 FT.                |
| DF-54-VI      | 41,001-52,000 ACFM       | 350 TEFC                     | 4 FT.              | 5 FT.                |
| DF-64-VII     | 52,001-56,000 ACFM       | 400 WP-II                    | 4 FT.              | 6 FT.                |
| DF-64-VIII    | 56,001-62,000 ACFM       | 450 WP-II                    | 4 FT.              | 6 FT.                |
| DF-84-IX      | 62,001-100,000 ACFM      | 500-700 WP-II                | 4 FT.              | 8 FT.                |

**FIGURE 8**  
**HEAF FILTER DRUM AND MEDIA**



## COOLING CHAMBERS

Because the HEAF units are filtration devices, they cannot remove gas phase organic compounds from a gas stream. Thus, all organic matter must be condensed into liquid droplets before it can be filtered from the gas stream. Many organic compounds can be condensed at a temperature below about 200° F. Some lighter oils can be condensed at a temperature of approximately 120° F. It is very uncommon for HEAF units to require a temperature less than 120° F at the inlet to achieve adequate collection efficiency. As a result, Verantis offers a complete line of evaporative cooling chambers for use with the HEAF units which are capable of reducing the exhaust gas temperatures from any industrial process to at least 120° F. For special applications, where lower inlet temperatures to the HEAF unit are necessary, Verantis designs special cooling chambers.

All connecting ductwork must be provided by the customer. In addition, piping between the water source, the pump, the tank, and the nozzles must be installed by the customer. A drain pipe must be connected to the cooling chamber to return cooling water to the recirculation tank.

Table V provides guideline dimensions for typical HEAF applications where a cooling chamber is required. These dimensions are only for the chamber itself and do not include the tanks, Pumps, or controls. Dimensions can vary dramatically, depending on inlet gas conditions and space available. All of these cooling chambers include the following items:

1. Mild steel horizontal cylindrical vessel with flanged inlet and outlet
2. All necessary spray nozzles manifolded into a common flanged connection.
3. Recirculation tank with or without agitator, depending upon presence or absence of insoluble solids, and with cast iron centrifugal ANSI process pump capable of delivering 40 psig cooling liquid to the cooler. Recirculation pump is equipped with TEFC 460v, 3 phase,

60 Hz drive motor.

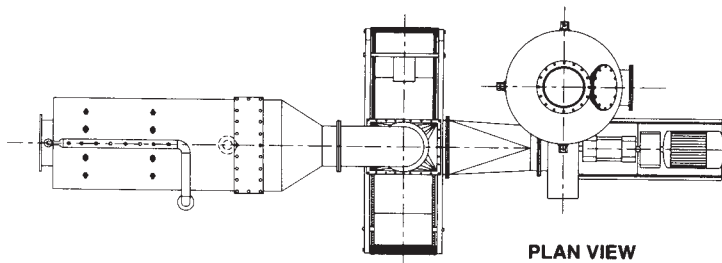
4. Decant tank used for applications requiring oil-water separation. This tank is baffled and equipped with decant manifold so that on intermittent basis, oils can be separated from the water and taken to re-use or disposal.
5. All piping for the recirculation pump and the decant loop is provided, including a flow-meter with flanged discharge to the cooler recirculation loop. Piping from flanged discharge to cooler nozzle manifold must be furnished by customer.
6. Liquid level control valve is provided for make up water to the recirculation tank.
7. All controls and instrumentation for the cooling chamber are included with the HEAF control panel.
8. Motor starters in NEMA 12 enclosures for pump and agitator (if equipped).

Figure 9 shows a typical cooling chamber and flat bed HEAF general arrangement for reference purposes.

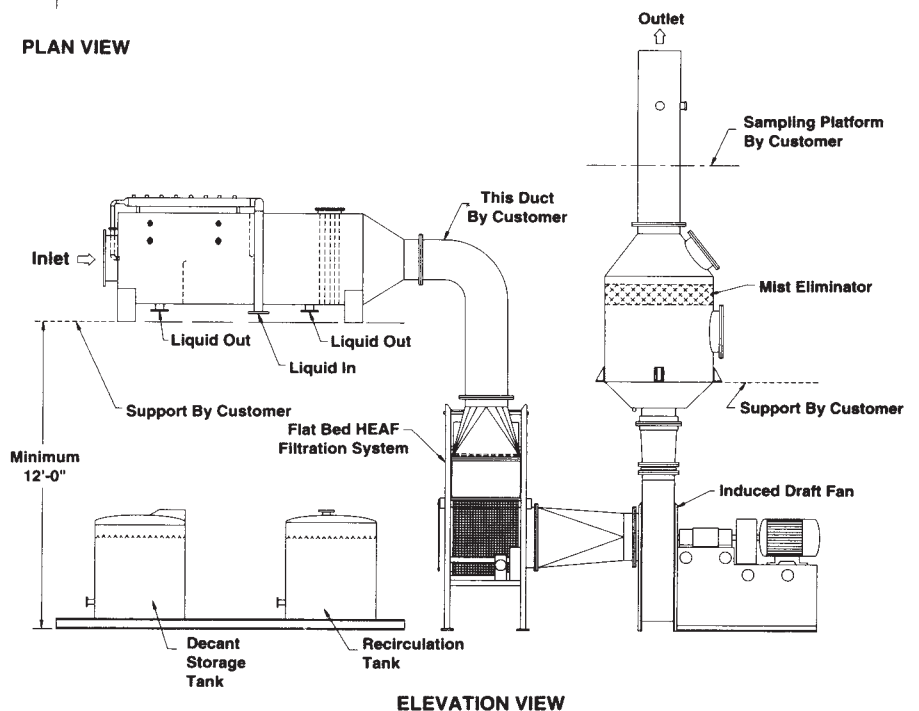
**TABLE V**  
**Verantis Cooling Chambers**

| MODEL# | MAXIMUM SATURATED GAS FLOW | OVERALL LENGTH OR HEIGHT* | VESSEL DIAMETER | INLET DIAMETER | OUTLET DIAMETER | SHIPPING WEIGHT |
|--------|----------------------------|---------------------------|-----------------|----------------|-----------------|-----------------|
| CC-1   | 480 ACFM                   | 132"                      | 10"             | 5 1/2"         | 5"              | 350 Pounds      |
| CC-2   | 690 ACFM                   | 132"                      | 12"             | 6 1/2"         | 6"              | 415 Pounds      |
| CC-3   | 950 ACFM                   | 132"                      | 14"             | 8"             | 7"              | 370 Pounds      |
| CC-4   | 1,240 ACFM                 | 132"                      | 16"             | 9"             | 8"              | 555 Pounds      |
| CC-5   | 1,560 ACFM                 | 132"                      | 18"             | 10"            | 9"              | 625 Pounds      |
| CC-6   | 1,740 ACFM                 | 132"                      | 20"             | 10"            | 10"             | 695 Pounds      |
| CC-7   | 3,480 ACFM                 | 162 1/2"                  | 28"             | 14"            | 14"             | 1,195 Pounds    |
| CC-8   | 6,260 ACFM                 | 209 3/4"                  | 36"             | 20"            | 18"             | 1,980 Pounds    |
| CC-9   | 6,960 ACFM                 | 217 3/4"                  | 38"             | 22"            | 20"             | 2,170 Pounds    |
| CC-10  | 8,700 ACFM                 | 228"                      | 50"             | 24"            | 24"             | 2,990 Pounds    |
| CC-11  | 17,400 ACFM                | 302"                      | 66"             | 32"            | 32"             | 5,230 Pounds    |
| CC-12  | 26,100 ACFM                | 313"                      | 80"             | 40"            | 38"             | 6,570 Pounds    |
| CC-13  | 34,800 ACFM                | 336 3/4"                  | 92"             | 46"            | 42"             | 11,900 Pounds   |
| CC-14  | 43,500 ACFM                | 347"                      | 102"            | 52"            | 48"             | 13,580 Pounds   |
| CC-15  | 52,200 ACFM                | 355 1/2"                  | 110"            | 56"            | 54"             | 15,010 Pounds   |
| CC-16  | 60,900 ACFM                | 362 1/2"                  | 118"            | 62"            | 60"             | 16,415 Pounds   |
| CC-17  | 69,600 ACFM                | 373"                      | 126"            | 66"            | 60"             | 18,035 Pounds   |

•Straight through flow design only. Contact factory for 90° angle units.  
**ALL DIMENSIONS ARE APPROXIMATE - DO NOT USE FOR CONSTRUCTION**



**FIGURE 9**  
**EVAPORATIVE GAS COOLER**







[www.verantis.com](http://www.verantis.com)